

### Features

- Standard schottky Rectifier
- Low forward voltage drop
- Low profile - typical body height 0.6 mm
- Moisture sensitivity: level 1, per J-STD-020
- RoHS compliant

### Mechanical Data

- Case:SOD-323HE
- Case material:molding compound meets  
UL 94V-0 flammability rating
- Polarity: color band denotes cathode end

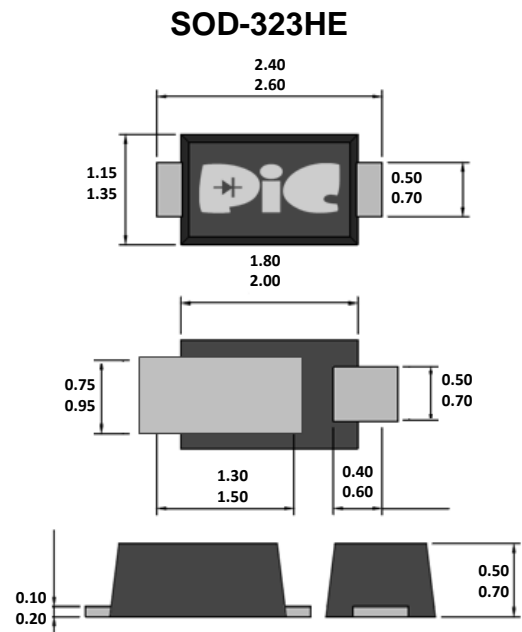

Unit:millimeter

### Maximum Ratings (TA=25°C unless otherwise noted)

Parameter	Symbol	Value	Unit
Maximum Recurrent Peak Reverse Voltage	$V_{RRM}$	60	V
Maximum RMS Voltage	$V_{RMS}$	42	V
Maximum DC Blocking Voltage	$V_{DC}$	60	V
Maximum Average Forward Rectified Current	$I_{F(AV)}$	1	A
Peak Forward Surge Current 8.3 ms Single Half Sine-Wave Superimposed on Rated Load (JEDEC Method)	$I_{FSM}$	22	A
Thermal Resistance, Junction to Ambient (Note 1)	$R_{\theta JA}$	173	°C/W
(Note 2)		125	
Junction Temperature Range	$T_J$	-65 to +150	°C
Storage Temperature Range	$T_{STG}$	-65 to +150	°C

Note:

1. FR-4 PCB, 2 oz. Copper, minimum recommended pad layout per
2. Polyimide PCB, 2 oz. Copper, minimum recommended pad layout per

### Electrical Characteristic (TA=25°C unless otherwise noted)

Parameter	Conditions	Symbol	Min.	Typ.	Max.	Unit
Reverse Voltage	$I_R=100\mu A$	$V_{(BR)R}$	60	-	-	V
	$I_F=0.1A$		-	-	0.45	
Forward Voltage	$I_F=0.7A$	$V_F$	-	-	0.58	V
	$I_F=1A$		-	-	0.64	
Reverse Leakage Current	$V_R=5V, T_J=25^\circ C$	$I_R$	-	-	5	$\mu A$
	$V_R=60V, T_J=25^\circ C$		-	-	100	
Junction Capacitance	$V_R=10V, f=1MHz$	$C_J$	-	38	-	pF

### Rating and Characteristics Curves

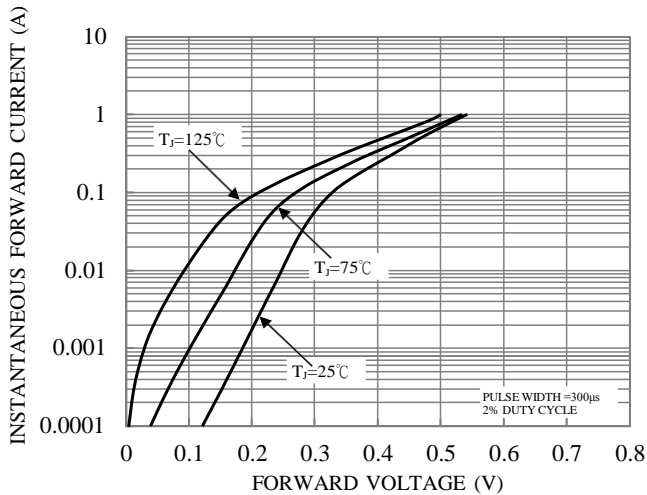

**Fig. 1-TYPICAL FORWARD CHARACTERISTICS**

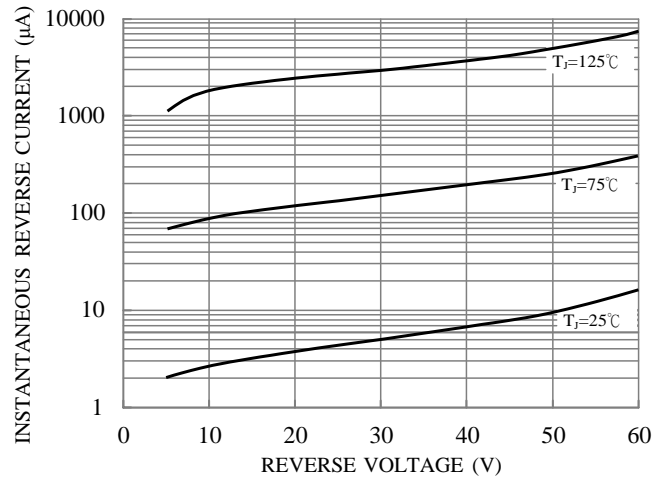

**Fig. 2-TYPICAL REVERSE CHARACTERISTICS**

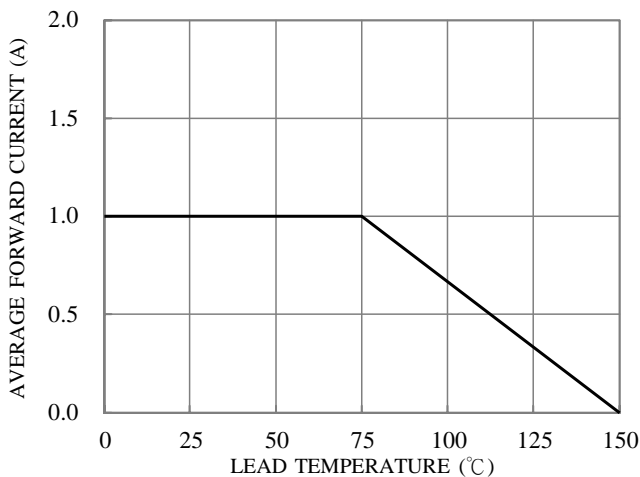

**Fig. 3-FORWARD CURRENT DERATING CURVE**

### Packaging Specifications

Package	W (mm)	A (mm)	B (mm)	C (mm)	d1 (mm)	d (mm)	E (mm)	F (mm)	P (mm)	P0 (mm)	P1 (mm)	T (mm)
SOD-123FL	8±0.2	2.00±0.1	3.85±0.1	1.1±0.1	1.0	1.50±0.1	1.75±0.1	3.5±0.05	4±0.1	4±0.05	2±0.05	0.23±0.05
SOD-123HE	8±0.3	2.00±0.1	4.00±0.1	1.45±0.1	1.0	1.55±0.1	1.75±0.1	3.5±0.05	4±0.1	4±0.10	2±0.05	0.23±0.10
SOD-323FL	8±0.2	1.37±0.1	2.75±0.1	0.85±0.1	1.00	1.60±0.1	1.75±0.1	3.50±0.05	4±0.1	4±0.10	-	0.20±0.10
SOD-323HE	8±0.3	1.60±0.1	2.80±0.1	0.95±0.1	1.0	1.50±0.1	1.75±0.1	3.5±0.05	4±0.1	4±0.10	2±0.05	0.23±0.10
SMAF	12±0.3	2.9±0.1	5.5±0.1	2.1±0.1	1.5	1.55±0.1	1.75±0.1	5.5±0.05	4±0.1	4±0.10	2±0.05	0.23±0.10
SMA-S	12±0.2	2.65±0.1	5.25±0.1	1.35±0.1	1.0	1.55±0.1	1.75±0.1	5.5±0.05	4±0.1	4±0.05	2±0.05	0.23±0.10
SMA-HE	12±0.2	2.65±0.1	5.25±0.1	1.35±0.1	1.0	1.55±0.1	1.75±0.1	5.5±0.05	4±0.1	4±0.05	2±0.05	0.23±0.10

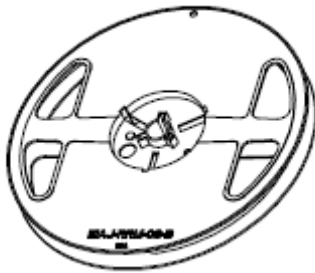
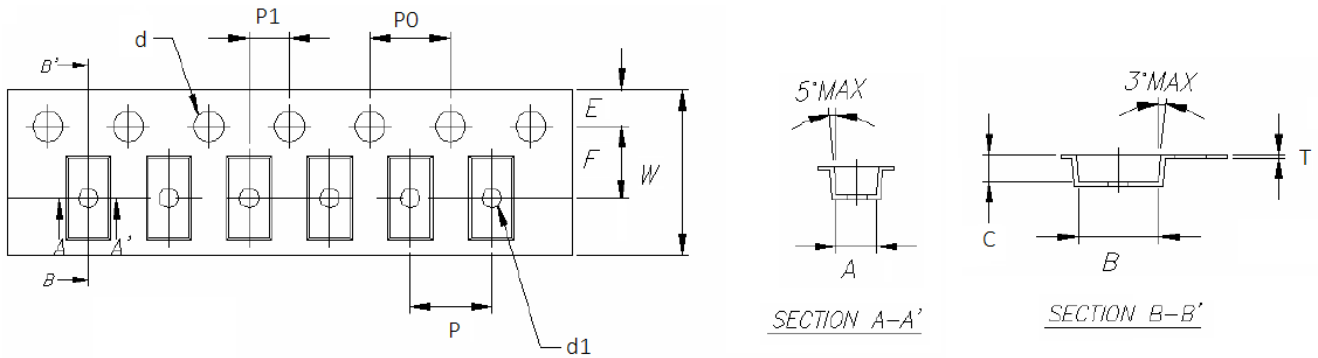

Package	D (max.) (mm)	D1 (min.) (mm)	D2 (mm)	G (min.) (mm)	W1 (min.) (mm)
SOD-123FL	178	50.0	13.0±0.2	8.4	11.4
SOD-123HE	178	50.0	13.0±0.2	8.4	11.4
SOD-323FL	178	50.2	13.0±0.2	8.0	11.5
SOD-323HE	178	50.0	13.0±0.2	8.4	11.4
SMAF	178	50.0	13.0±0.2	12.4	18.0
	330	50.0	13.0±0.2	12.4	18.0
SMA-S	178	50.0	13.0±0.2	12.4	18.0
SMA-HE	178	50.0	13.0±0.2	12.4	18.0

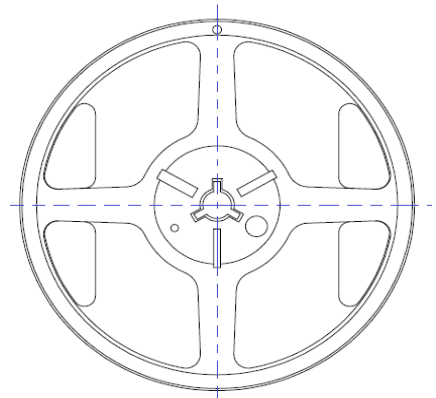
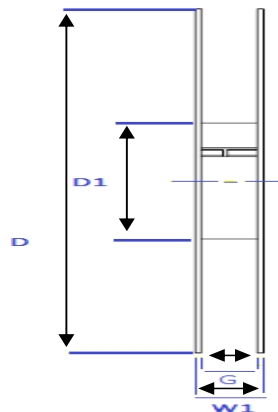
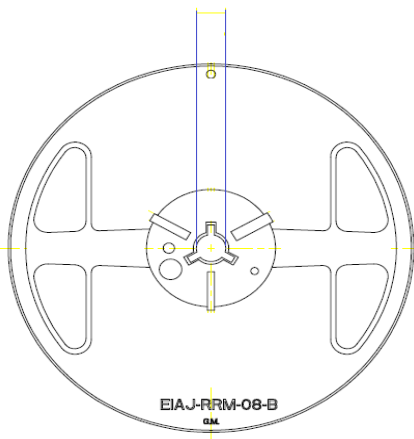

### Recommend IR Reflow Soldering Thermal Profile

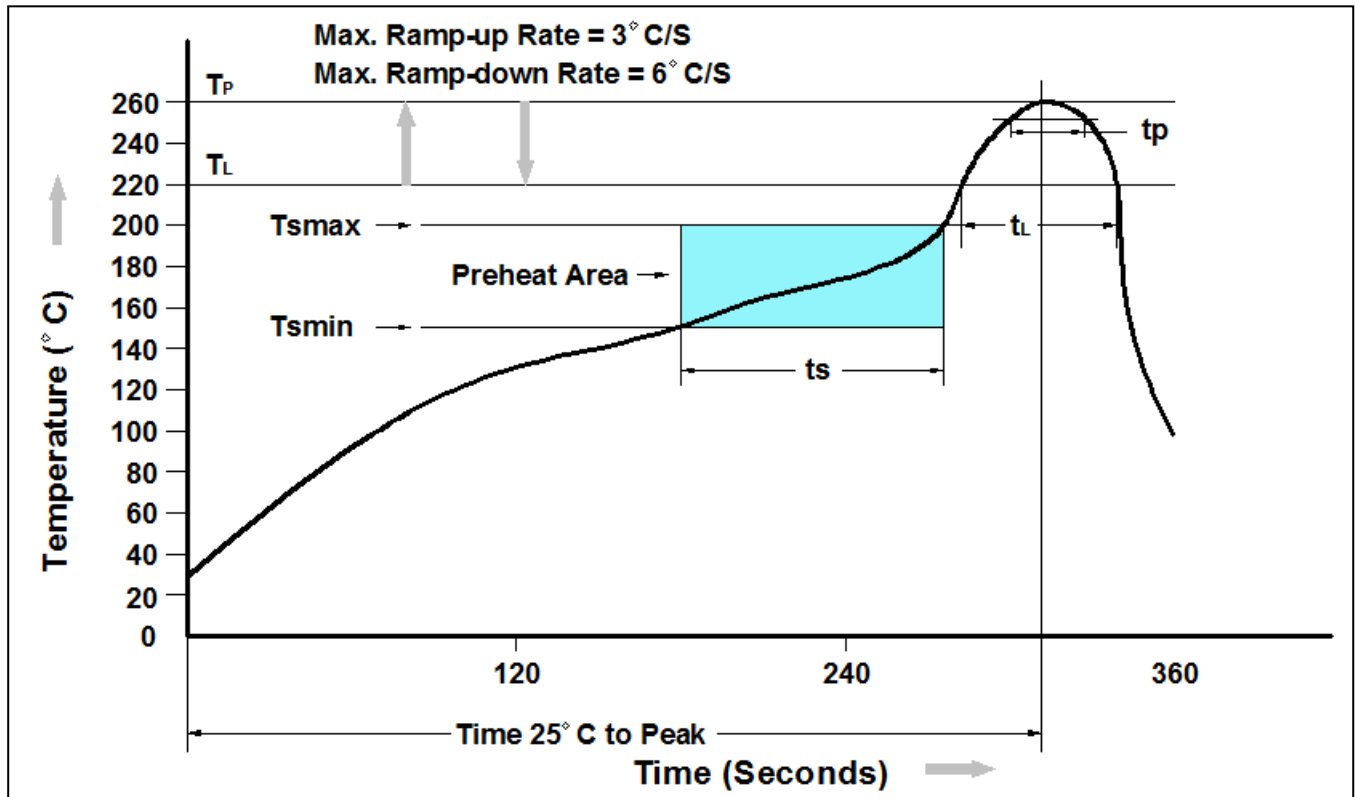

Profile Feature	Pb-Free Assembly Profile
Temperature Min. (T Amin)	150°C
Temperature Max. (Tsmax)	200°C
Time (ts) from (T Amin to Tsmax)	60-120 seconds
Average Ramp-up Rate (tL to tP)	3°C/second max.
Liquidous Temperature (TL)	217°C
Time (tL) Maintained Above (TL)	60 – 150 seconds
Peak Temperature	260°C +0°C / -5°C
Time (tp) within 5°C of actual Peak Temperature	30 seconds
Ramp-down Rate (TP to TL)	6°C/second max
Time 25°C to Peak Temperature	8 minutes max.

### Ordering Information

Part Number	Description	Quantity
SS1060HEW	SOD-323HE Reel	3,000pcs

### DISCLAIMER

- The information in this document and any product described herein are subject to change without notice and should not be construed as a commitment by Paceleader, Paceleader reserve the right to make changes to the information in this document.
- Though Paceleader make effort to improve product quality and reliability, Product can malfunction and fail due to their inherent electrical sensitivity and vulnerability to physical stress, it is the responsibility of the customer, when utilizing Paceleader products, to comply with the standards of safety in making a safe design for entire system and to avoid situation in which a malfunction or failure., In developing a new designs, customer should ensure that the device which shown in this documents are used within specified operating ranges.
- The information contained herein is presented only as a guide for the applications of our products. No responsibility is assumed by Paceleader for any infringements of patents or other rights of the third parties which may result from its use.